



IPv6 for AT&T Broadband

Chris Chase, AT&T Labs

Nov 2, 2011

AT&T Broadband

~15 million subscribers

- Legacy DSL, PPP subscribers, ATM aggregation
 - Not many CPE IPv6 capable
 - Customer owned, unmanaged CPE
- ~4 million U-Verse subscribers
 - Next gen broadband: FTTN, FTTP; Ethernet and DHCP
 - Managed CPE
 - Most CPE IPv6 upgradeable



IPv6 Service

Initially via 6rd for legacy and U-Verse

- Managed CPE
- Automatically enabled (no “opt-in” required)

Later: DHCPv6 on WAN

- 6PE in metro

LAN side service same for both



IPv6 Service via 6rd: Tunneling v6 through v4

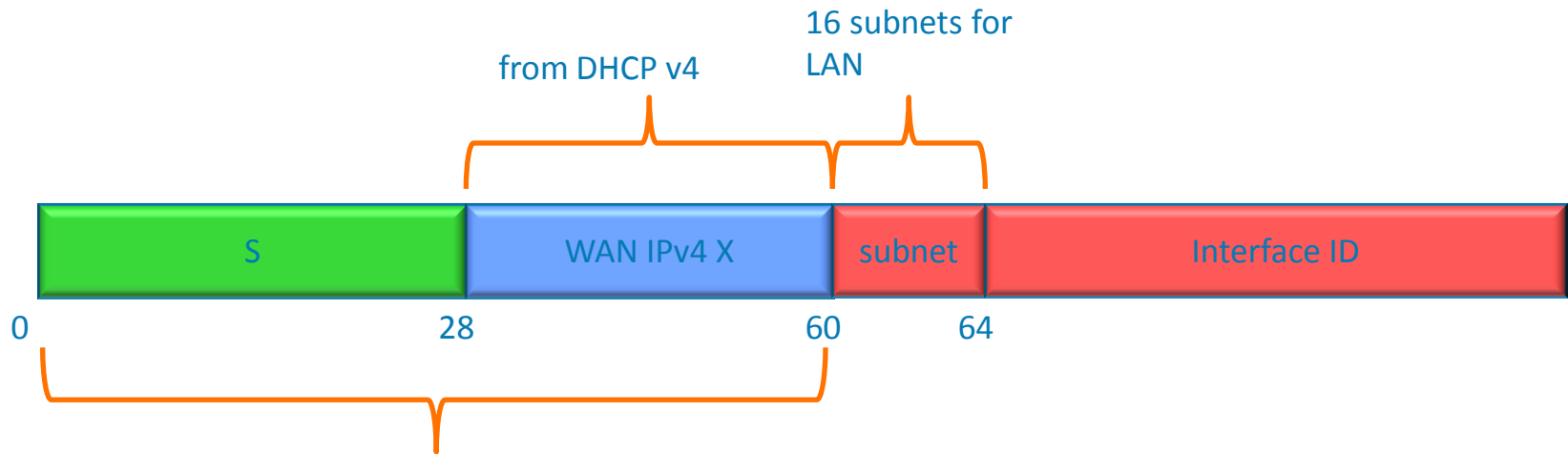

Delegated Z/60 for CPE

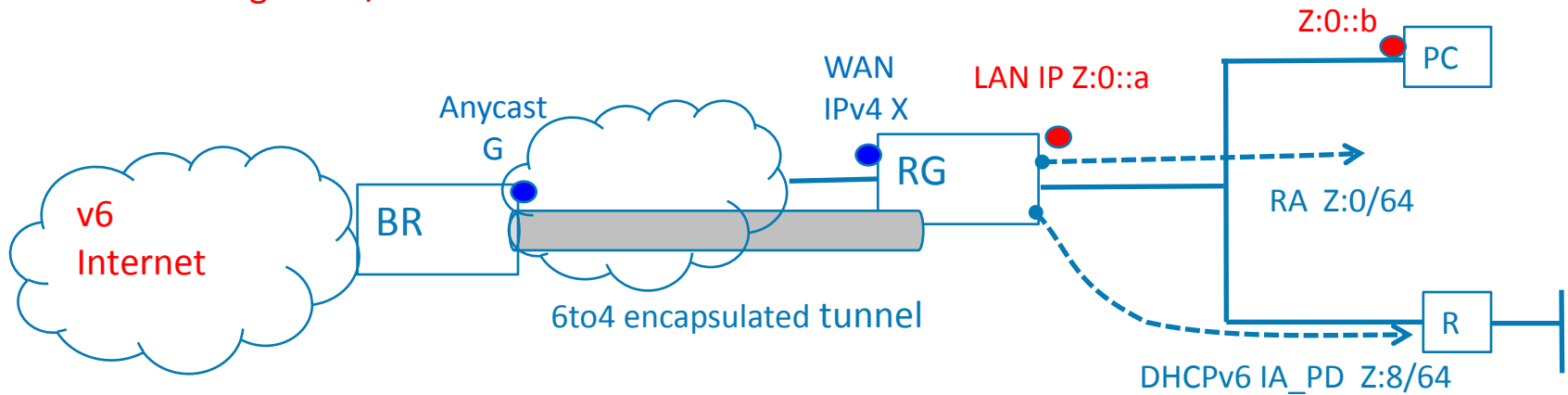

v6 Sub to v6 Internet

- CPE sends all WAN-bound v6 over tunnel
- Uses v4 WAN IP as source of tunnel
- ALL traffic “anchored” through BR
 - BBF: Device.IPv6rd.InterfaceSetting.{i}.AllTrafficToBorderRelay

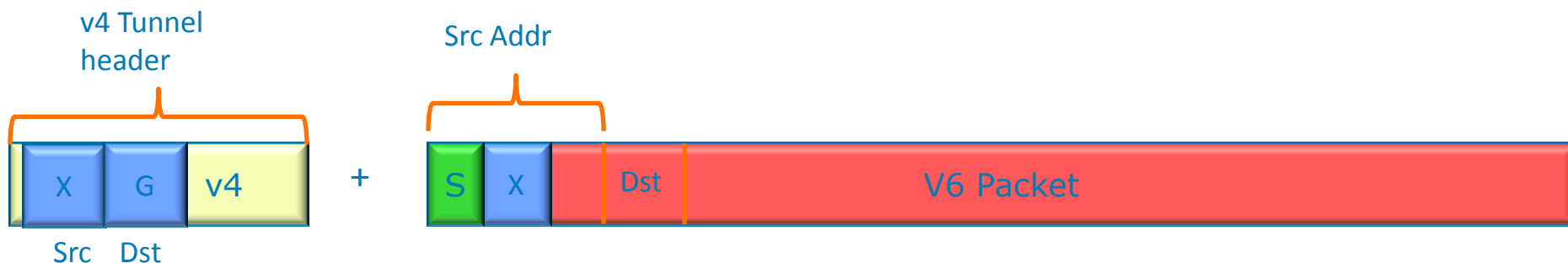

G = BR Anycast IP

Support BR continuity test and BR discovery through anycast ping



v6 Internet to Subscriber

v6 Prefix S announced from BR to v6 Internet

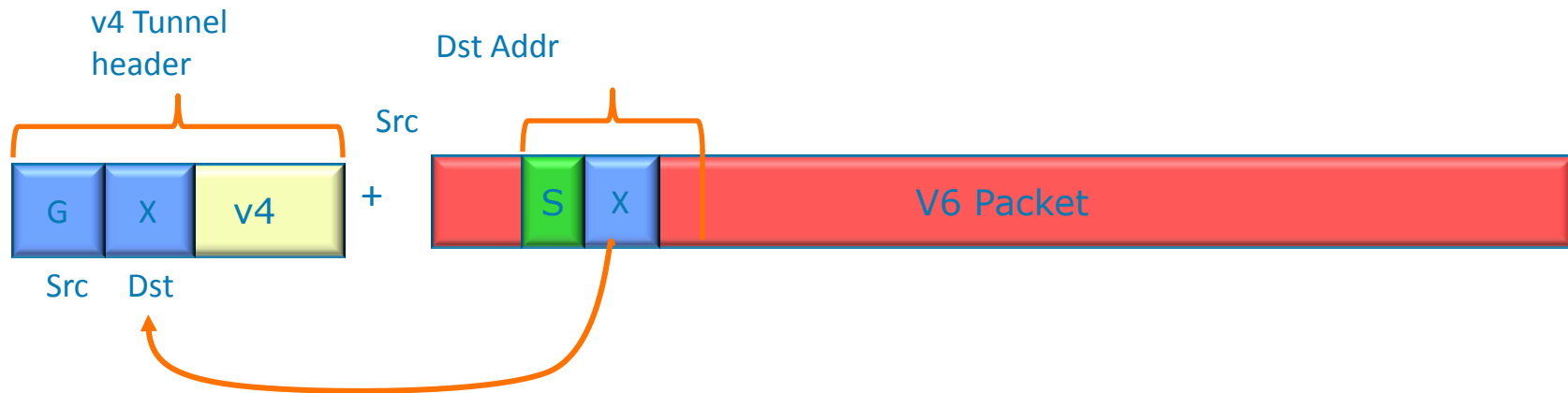

Traffic destined to S at BR: look for embedded IPv4 copy to v4 tunnel header



SP Prefix and Multiple 6rd Domains

If multiple private IPv4 instances deployed

- Then require multiple SP prefixes
- Require OSS tracking of sub to domain mapping

Prefer one 6rd domain

- Single SP /28 for public and private v4 subs
- Anycast BRs spread around the country



DNS

May need separate DNS infrastructure for v6 enabled subscriber

- Use separate DNS server IP address for v6 enabled subscribers
- Allows for AAAA white listing if necessary

Rely on IPv4 DNS for AAAA resolution

- CPE may not support DNSv6 initially
- Need a uniform way to inform LAN clients of DNS server v6 addresses
 - Today all clients get v4 DNS servers from DHCP from CPE
 - CPE gets DNS servers from PPP or DHCP
 - These point to the CPE as the resolver;
 - DHCPv6 versus RA Option (RFC6106) – undecided; future release



6rd Configuration

Managed CPE

- Configured using TR-69 rather than DHCP

Unmanaged or customer owned router

- Legacy services are PPP and not DHCP based
 - DNS learned via PPP
- Upgrading BRAS to support DHCP relay is a non-starter
- TR-69 may an option
- Possibly via DHCP Inform msg to a unicast IPv4 to obtain 6rd and DNS
- ISP certified 6rd CPE
 - Either fulfilled by ISP preconfigured with DHCP IP
 - Or user entered DHCP IP



Rollout

Field upgradeable CPE

- Can be rolled out geographically with all CPE enabled based on OPs plans
 - Off by default until OPs enables
 - No need for customer to trigger an order
- Matched with BR capacity
- Allow customer to disable

Replacement CPE

- Customer owned
 - Require customer order trigger for new CPE
- ISP owned
 - Require business case to replace



Simple and Business Broadband Services

Single host model

- Care supports only a single host attached to CPE
 - Could be a single PC or router
 - Can still provide IA_PD

Business services

- Get a “static” public v4 subnet besides the dynamic WAN IPv4
- Allow 6rd tunnel to be sourced from an interface with the static public IPv4

